

BODY ARMOR 4X4

**ECO-SERIES REAR BUMPER
2010-16 DODGE RAM 2500/3500
PART # DG-2963**

Body Armor 4x4
272 Corporate Terrace St.
Corona, CA 92879
951-808-0750
Customer Service hours:
M-TH: 7:30am to 4:30 PM Pacific Time
Friday: 8 AM – Noon Pacific Time

PARTS LIST:

1	Heavy Duty Rear Bumper Assembly	8	12mm Nylon Lock Nuts
1	Push in License Plate Light	4	8mm x 40mm Hex Bolts
2	Plastic Plugs for license plate mount	4	8mm x 28mm x 3mm Flat Washers
4	Sensor Hole Plugs	4	8mm Lock Washers
8	12-1.75mm x 50mm Hex Bolts	8	4mm x 10mm Button Head Bolts
16	12mm x 37mm x 3mm Flat Washers	1	4mm Wrench

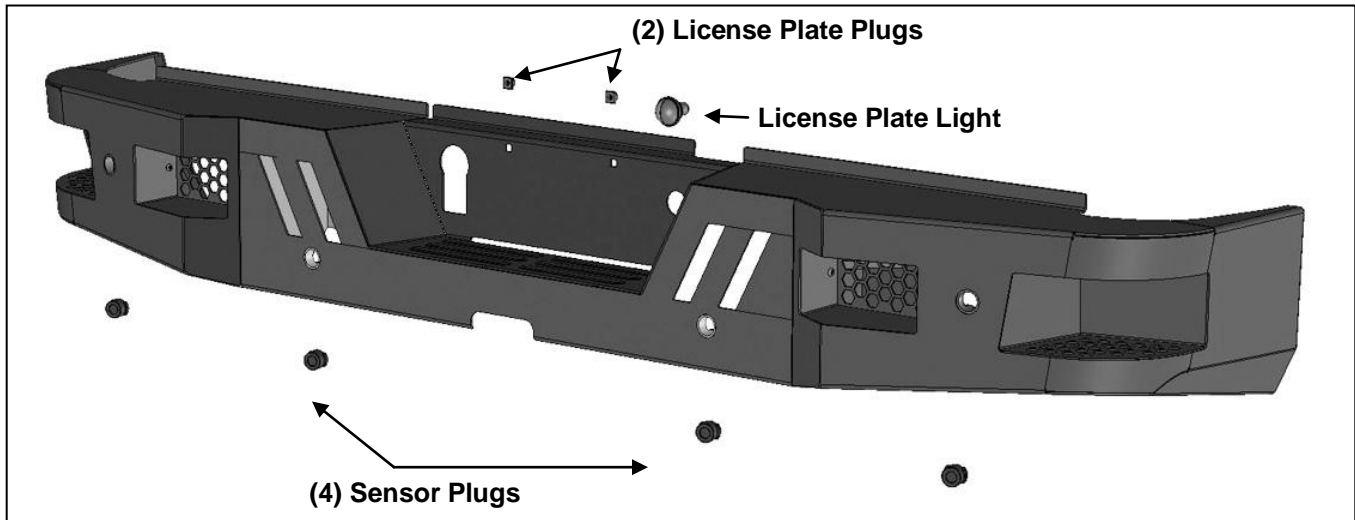

PROCEDURE:

REMOVE CONTENTS FROM BOX. VERIFY ALL PARTS ARE PRESENT. READ INSTRUCTIONS CAREFULLY BEFORE STARTING INSTALLATION. BUMPER IS HEAVY, ASSISTANCE IS HIGHLY RECOMMENDED TO AVOID POSSIBLE INJURY OR DAMAGE TO THE VEHICLE.

1. Start installation by unplugging the license plate lights, towing harness plug and sensors if equipped, **(Figure 1)**. Remove the license plate. Remove the outer towing harness plug, **(Figure 2)**. On models with back up sensors, remove the sensors from the plastic sleeves, **(Figure 3)**. Move the wiring harness away from the bumper.
2. Place blocks or jack stands under the bumper to support it during bumper bolt removal. Once the bumper has been safely supported, remove the bumper bolts and slide the rear bumper off of the end of the frame, **(Figures 4—6)**. **WARNING!** Assistance is required to hold the bumper in place during hardware removal and to prevent the bumper from falling.
3. With assistance, position the Bumper Assembly up and over the bumper brackets on the ends of the frame, **(Figures 6 & 7)**. Temporarily support the weight of the Bumper Assembly. **WARNING:** To avoid possible injury or damage to the vehicle, do not proceed until the Bumper is fully and safely supported.
4. Line up the (2) outer holes in the passenger side frame mounting bracket with the (2) holes in the Mounting Plate. Attach the Bumper to the frame bracket with (2) 12mm Hex Bolts, (4) 12mm Flat Washers and (2) 12mm Nylon Lock Nuts, **(Figures 7 & 8)**. Leave hardware loose at this time. Repeat to attach the driver side of the Bumper to the frame bracket.
5. Next, line up the (2) inner holes on the passenger side frame bracket to the mounting plate on the Bumper. Select the correct installation.

Models with 8mm hex nuts welded onto the back of the frame bracket:

- a. Use (2) 8mm Hex Bolts, (2) 8mm Lock Washers and (2) 8mm Flat Washers to attach the passenger side of the Bumper to the frame bracket, **(Figures 4 & 7)**. Repeat this Step to attach the driver side of the Bumper to the frame bracket. Do not fully tighten hardware.

Models without 8mm welded hex nuts (open holes):

- b. Use (2) 12mm Hex Bolts, (4) 12mm Flat Washers and (2) 12mm Nylon Lock Nuts to attach the passenger side of the Bumper to the frame bracket. Repeat this Step to attach the driver side of the Bumper to the frame bracket. Leave hardware loose.
- c. **NOTE:** On some models/years, the frame bracket may only be equipped with outer mounting holes. Adjust installation accordingly, **(Figure 5)**.
6. Level and adjust the HD Bumper and fully tighten all hardware.
7. Snap the plug for the trailer harness into the opening in the HD Bumper. If necessary, use a flat blade screwdriver to carefully pry the metal clips out to grab the edge of the openings in the Bumper. Reattach the wiring harness to the back of the plugs.
8. Select the included (2) push-in plugs to attach the license plate to the Bumper, **(Figure 9)**.
9. Select the included snap in Universal License Plate Light. Insert the Light into the mounting hole in the bumper, **(Figure 9)**. Connect the wire harness to the License Plate Light. Tie down all wiring harnesses and seal off any open wiring connection.
10. Remove screens in light housings for more room around lights as needed, **(Figure 9)**.
11. **Models with bumper mounted sensors:**
 - a. Remove the rubber plugs from the sockets in the bumper assembly. Push the sensor in from the back of the bumper. Secure each sensor to the socket with (2) 4mm x 10mm Button Head Screws, **(Figure 10)**. **IMPORTANT:** Sensors fit snug in sockets. The 4mm Screws are used to apply slight pressure to lock the sensors in place. Tighten both screws evenly until they touch the sensor body only. Do not overtighten screws or damage to sensors will result.
12. Use the included Wire Ties to secure the wiring harness to the bumper and frame.
13. Do periodic inspections to the installation to make sure that all hardware is secure and tight.

To protect your investment, wax this product after installing. Regular waxing is recommended to add a protective layer over the finish. Do not use any type of polish or wax that may contain abrasives that could damage the finish. Mild soap may be used to clean the Heavy Duty Bumper assembly.

Passenger side installation pictured

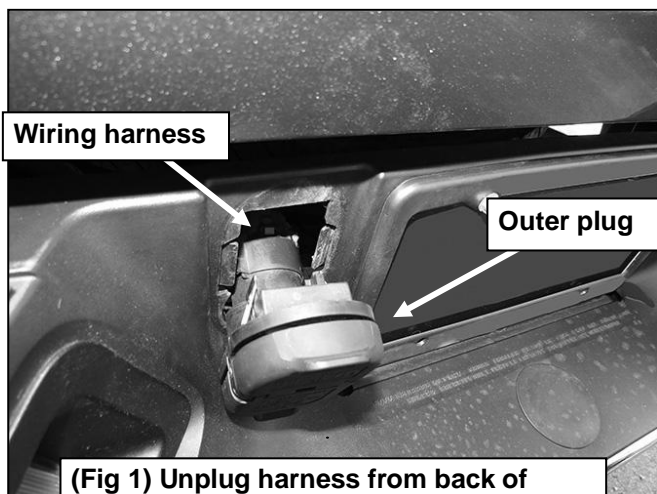

(Fig 1) Unplug harness from back of trailer connector then remove outer plug

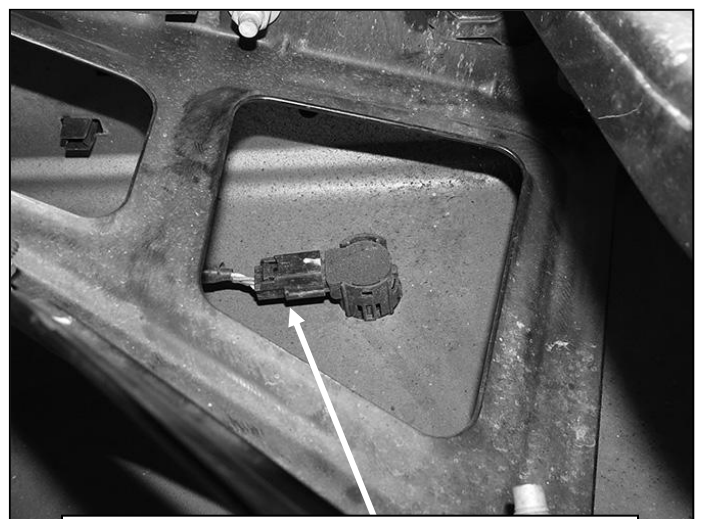

(Fig 2) Unplug the sensor first then remove the sensor from the mounting sleeve



(Fig 3) Remove the mounting sleeve (right) from each sensor location in bumper

WARNING! Do not remove bumper bolts unless the bumper is properly supported on blocks or stands or the bumper may fall.

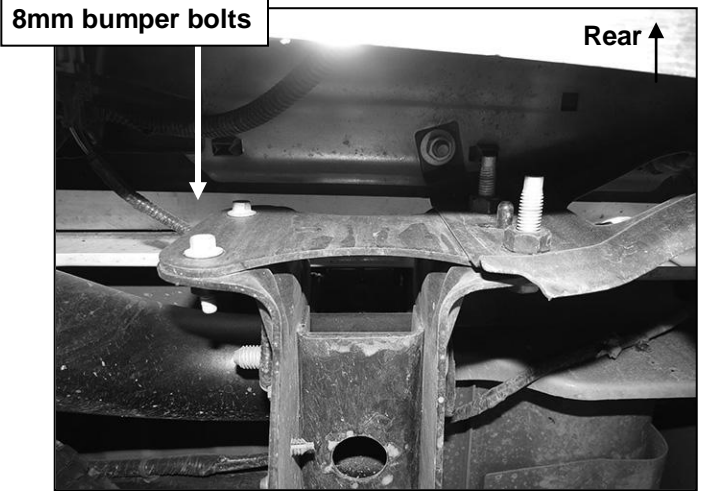

(Fig 4) Example of factory bumper bracket with 8mm hex nuts (left) welded onto back of bracket

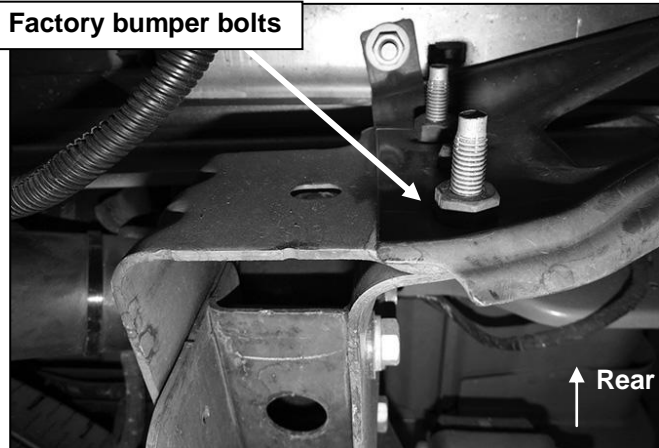

(Fig 5) Example of factory bumper bracket with (2) hex bolts only (right) pictured from below bumper

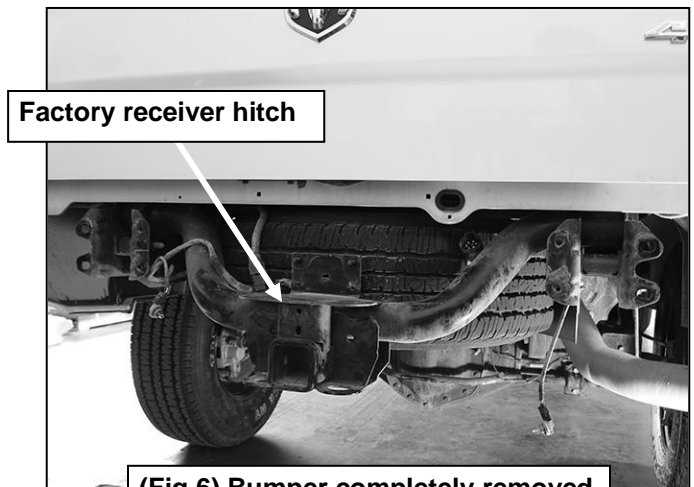

(Fig 6) Bumper completely removed

- (2) 12mm Hex Bolts**
- (4) 12mm Flat Washers**
- (2) 12mm Nylon Lock Nuts**

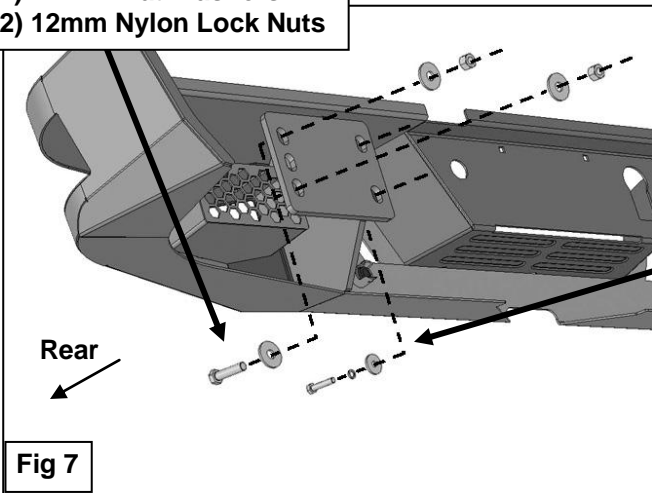
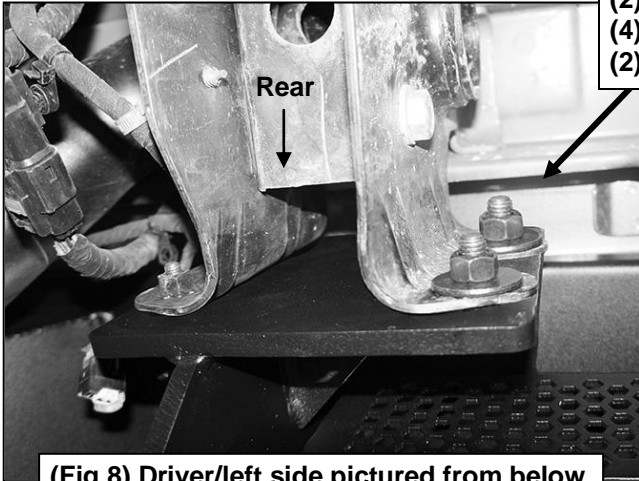

Fig 7

- On inner side of bracket, use:**
- (2) 12mm Hex Bolts**
 - (4) 12mm Flat Washers**
 - (2) 12mm Nylon Lock Nuts**
 - or**
 - (2) 8mm Hex Bolts**
 - (2) 8mm Lock Washers**
 - (2) 8mm Flat Washers**

WARNING! Do not crawl under bumper unless the bumper is properly supported on blocks or stands or the bumper may fall.

**ECO-SERIES REAR BUMPER
2010-16 RAM 25-3500**



(2) 12mm Hex Bolts
(4) 12mm Flat Washers
(2) 12mm Nylon Lock Nuts

(Fig 8) Driver/left side pictured from below

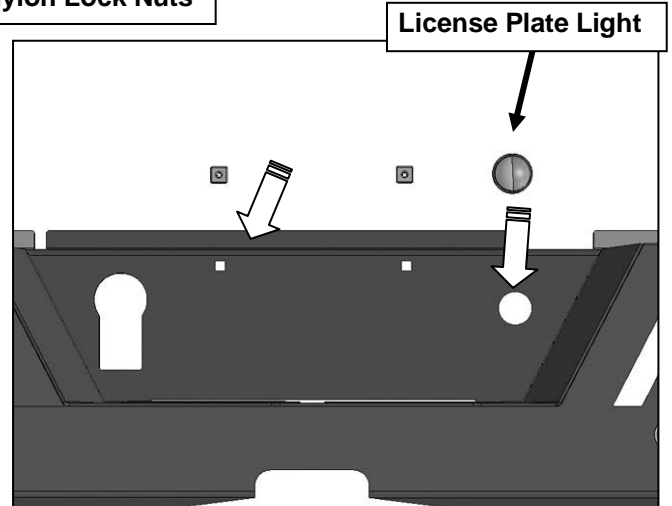

(Fig 9) Push plastic plugs into holes for license plate

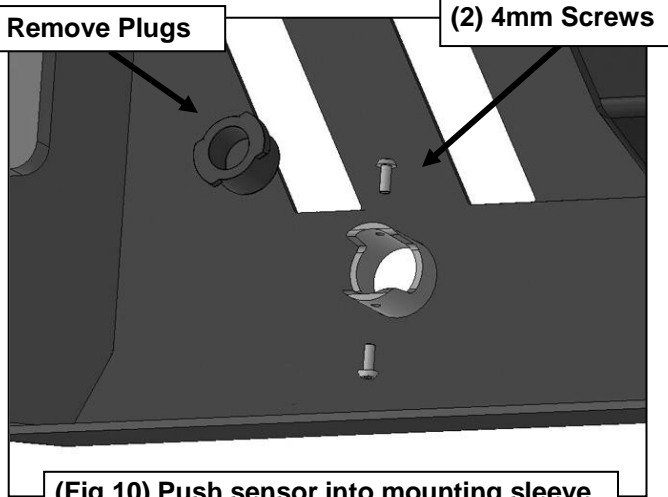

(Fig 10) Push sensor into mounting sleeve. Use 4mm Screws to lock sensor in place.

IMPORTANT: Sensors fit snug in sockets. The 4mm Screws are only used to apply slight pressure to lock the sensors in place. Tighten both screws evenly until they touch the sensor body only. Do not overtighten screws or damage to sensors will result.

Remove screens if necessary for additional clearance around or access to lights

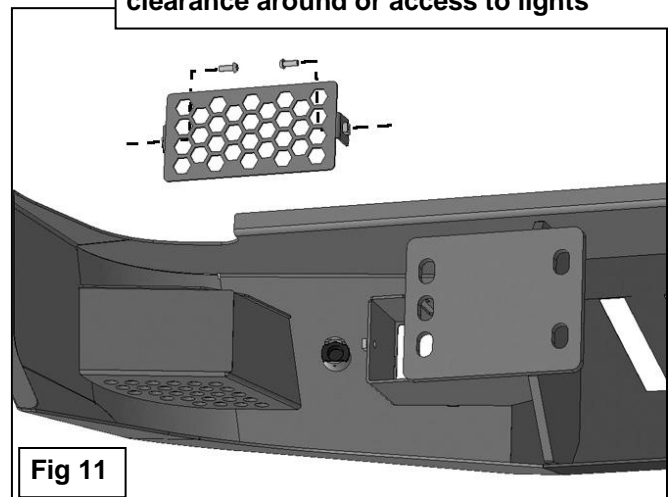

Complete Installation

1 PAIR UNIVERSAL DUAL LIGHT INSTRUCTIONS

PARTS LIST:

Qty	Description	Qty	Description
2	Lights (Sold Separately)	2	8mm Lock Washers
1	Wiring Harness (Sold Separately)	4	6mm x 16mm Socket Head Cap Screws
2	Low Profile Light Brackets	4	6mm Nylon Lock Nuts
2	8-1.25mm x 20mm Hex Bolts	1	Wrench
2	8mm x 24mm x 2mm Flat Washers		

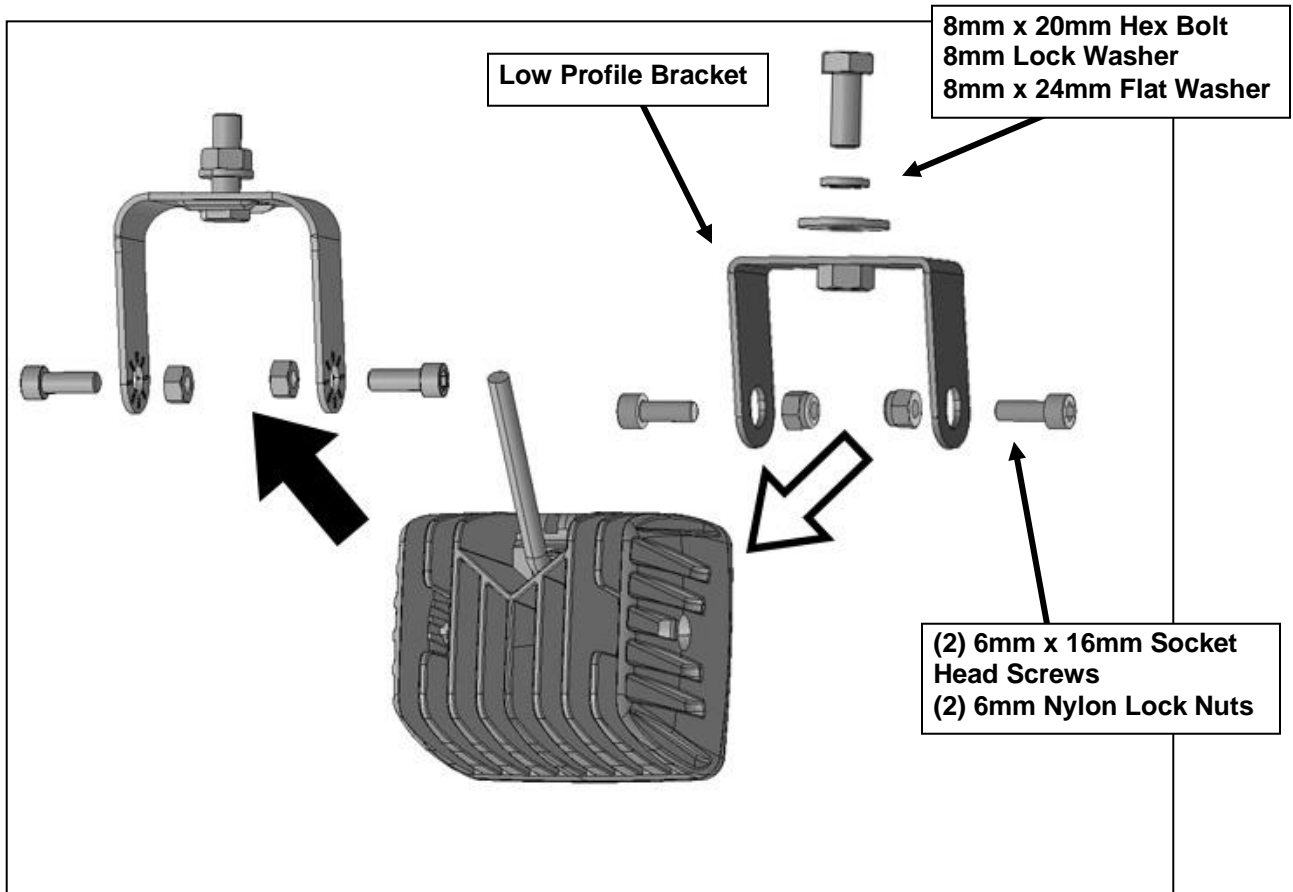

PROCEDURE:

- 1. REMOVE CONTENTS FROM BOX. VERIFY ALL PARTS ARE PRESENT. READ INSTRUCTIONS CAREFULLY. DRILLING IS REQUIRED. ELECTRICAL KNOWLEDGE IS HIGHLY RECOMMENDED.**
- Select (1) Light. Remove the factory installed bracket and hardware from the light.
- Slide (2) 6mm Nylon Lock Nuts into the slots in the back of the light. Select (1) Low Profile Bracket. Attach the Bracket to the light with the included (2) 6mm Socket Head Screws. Snug but do not fully tighten hardware at this time.
- Insert the light into the opening in the bumper and up to the slots in the top of the opening. Attach the light and bracket to the top of the opening with (1) 8mm x 20mm Hex Bolt, (1) 8mm Lock Washer and (1) 8mm x 24mm Flat Washer. Snug but do not fully tighten hardware at this time. **NOTE:** The screen attached to the back of the opening in the bumper is removable (see instructions for bumper installation). Depending on light size and quantity to install, it may be necessary to remove the screen before installation for best results. Repeat Steps as necessary for all light installations.

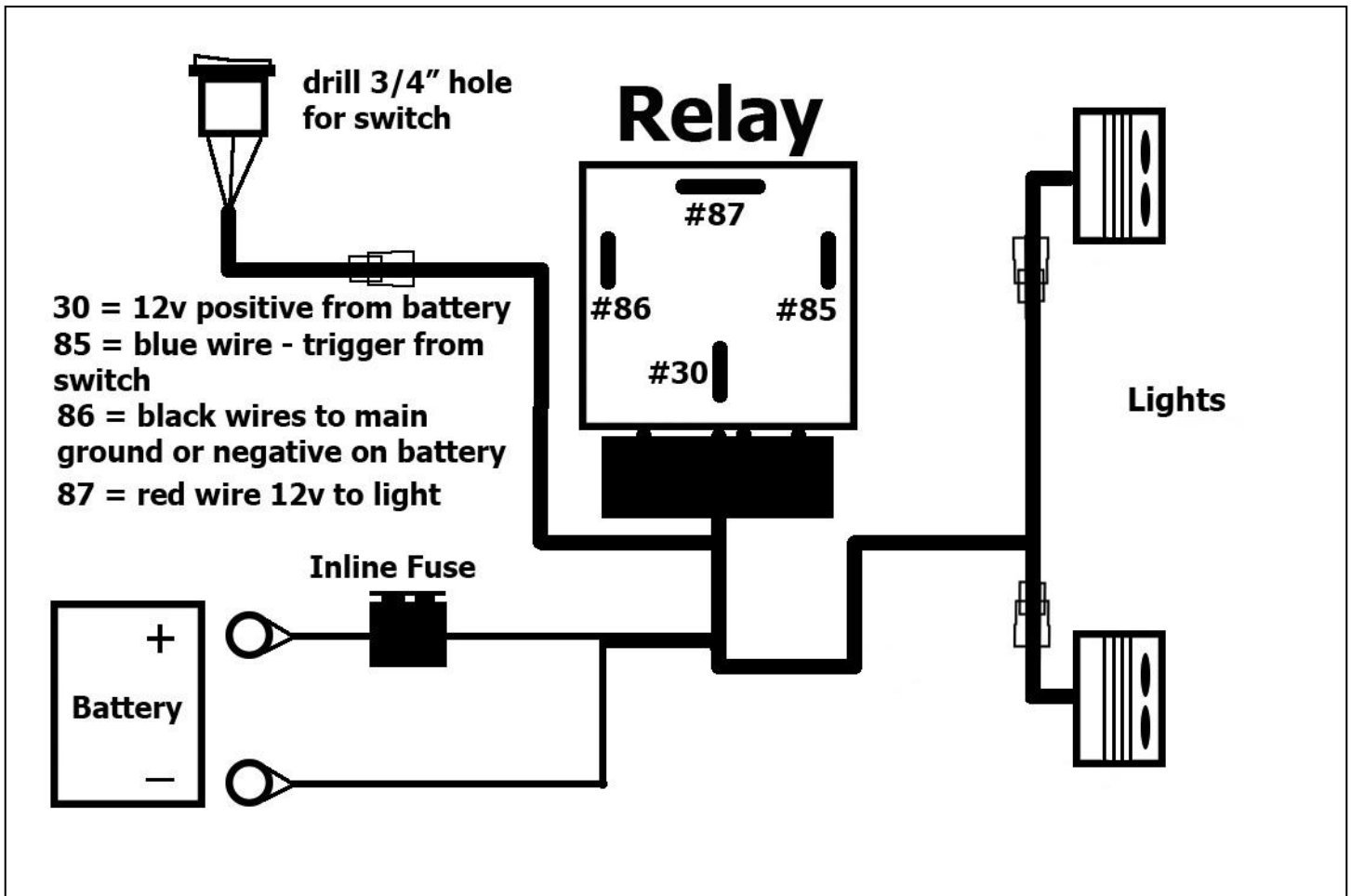

5. Open hood and disconnect battery.
6. Unwrap preassembled wiring harness. Disconnect the plug in the harness leading to the lighted switch. Locate suitable mounting location for switch. Drill 3/4" hole in panel to mount switch. **IMPORTANT:** Do not drill any holes in panel until back of location is properly checked for clearance. Use of safety goggles is required.
7. Run switch harness through firewall on vehicle. Drill hole through firewall as required for harness plug. Highly recommend use of rubber grommet (not included) to protect harness. Feed switch harness plug through hole in firewall. Seal firewall with silicone as necessary.
8. Attach Relay and main harness to suitable location near battery (firewall or inner fender for example). Do not connect to battery at this time.
9. Attach switch plug to switch harness and tie harness away from anything that could damage harness.
10. Run the prewired light harness down to the light. Plug harness into prewired plug on each light. Tie wiring harness away from anything that could damage harness.
11. Attach the fused red positive and black negative wires on the main harness to the battery. **NOTE:** Attach black negative wire to negative terminal on battery or suitable chassis ground.
12. Reattach battery cables to battery. Installation is complete.
13. Adjust lights for best results and fully tighten all hardware.
14. Do periodic inspections to the installation to make sure that all hardware is secure and tight and all wiring harnesses are properly secured and free from excessive movement.